



DEPARTMENT OF PUBLIC SERVICE
5330 Seaman Road
Oregon, Ohio 43616
(419) 698-7047
FAX (419) 691-0241

October 11, 2024

ADDENDUM No. 4
STREET DEPARTMENT GARAGE FACILITY - 2024

City of Oregon
Department of Public Service

BIDS TO BE OPENED: Thursday, October 17, 2024 at 11:00 A.M.

Plan holders of the City of Oregon's Street Department Garage Facility – 2024 are hereby notified of the following amendments to the Contract Documents. The following additions, alterations, deletions and/or clarifications shall be part of the Base Bid as much as if they were originally included in the Contract Documents. This Addendum No. 4 is hereby made a part of the Contract Documents.

TO ALL BIDDERS: This addendum supplements and amends the original drawings and project manual and shall be taken into account in preparing proposals and shall become a part of the contract document. This addendum must be received for on the proposal form.

NOTE: Addenda are emailed only to official plan holders who obtained plans and specifications from the Newfax Corporation, Inc., who is responsible for distribution of said plans and specifications. Each Prime Contractor is responsible for notifying subcontractors of any addenda issued.

Per the Notice to Bidders: All bids must be made on the proposal forms, which with the contract documents, including Specifications and Bid Forms must be obtained from [Newfax Corporation, Inc.](#), 333 West Woodruff Avenue, Toledo, OH 43604, P (419) 241-5157, M-F 8:30 am to 4:30 pm. Contact [Newfax Corporation](#) for cost of documents. Deposits are non-refundable.

CONTRACT CHANGES

1) PROJECT BID FORM

- Replace **PAGE 12** in the Project Bid Book with the attached **REVISED BID FORM PAGE 12 ADDENDUM #4** with revised amount for Allowance #2 for Item #72 - 2-Post Lift.

2) Specification 01 21 00 ALLOWANCES

- Replace original section 01 10 00 ALLOWANCES with attached.

3) All floor slabs and aprons in all areas to be 8" deep reinforced with 4x4-W4.0XW4.0 W.W.F. placed at 3" below top of slab using rebar chairs spaced at 36" o/c each way.

ANSWERS TO SUBMITTED QUESTIONS

- 1) **Bidder Question:** *Please confirm size and type of wall girts to be used. Structural shows 2x6, architectural 2x4 and a few notes call for girts to be pressure treated but not all specify that.*

Architect/Engineer Response: All wall girts to be 2x6 and pressure treated.

- 2) **Bidder Question:** *Please confirm how 2x12's and LVL's are to be attached to the 6x6 columns.*

Architect/Engineer Response: Fasten each end of 2x12 to columns with (10-16d nails, each side) and (14-10d nails each ply of 2-ply 1½"x14 " LVL)

ADDENDUM No. 4
STREET DEPARTMENT GARAGE FACILITY - 2024

- 3) **Bidder Question:** *Please confirm plywood roof sheathing thickness. Structural calls for 23-32", Architectural shows 5/8"*

Architect/Engineer Response: All roof sheathing to be 23/32"

- 4) **Bidder Question:** *Please confirm what type of corner guards are required at the interior liner panel corners that are shown to receive corner guards.*

Architect/Engineer Response: See specification section 10 26 13 for FRP wall protection and corner guards. Corner guards for wash bay PVC liner panels are included within spec section 06 60 10 PVC Paneling under 2.5 Accessories and corner trim is by the manufacturer for all metal liner panels corners.

- 5) **Bidder Question:** *In lieu of solid 6x6 PT posts, 4 Ply laminated posts would provide a much straighter, more stable, stronger post. At the lengths required for the project the laminated posts should provide an overall better end product for the owner. Would the Owner / Arch / Eng consider specifying these columns in lieu of solid 6x6 PT posts?*

Architect/Engineer Response: 4 Ply pressure treated laminated posts are an acceptable alternative to solid 6x6 pressure treated posts – provide hot dipped galvanized SWP64 STURDI-WALL plus bracket With 4 ply laminated columns.

- 6) **Bidder Question** *Some of the posts on the end walls are 30'+ long, the solid 6x6's are going to bow and twist and I don't think it's going to end up being an acceptable product no matter who puts them in.*

Architect/Engineer Response: 4 Ply pressure treated laminated posts are an acceptable alternative to solid 6x6 pressure treated posts

- 7) **Bidder Question** *You've specified Special-Lite for the FRP doors; however you do not specify which model. Can you clarify please?*

Architect/Engineer Response: AF100 by special lite, 4900 FRP Doors by Capitol Aluminum and equals by Cross Aluminum Products, Kawneer, and YKK.

- 8) **Bidder Question** *Please see the information from BendPak regarding the lifts. "Thank you for your interest in our equipment. We no longer make the XPR-18CL. Our new models are- 16AP and 20AP." Please advise.*

Architect/Engineer Response: BendPak advised they are in the process of a switchover on 2-post models and the availability of the XPR-18CL is dependent on the timing of our project. If the XPR-18CL is not available, the city would opt for the new model BendPak 20-AP. The allowance for Item #72 - 2-Post Lift has been adjusted to now be \$25,000 on page 12 of the revised bid form (attached).

ADDENDUM No. 4

STREET DEPARTMENT GARAGE FACILITY - 2024

- 9) ***Bidder Question*** *Can you review the 2 attached products as equal alternates for the metal roofing and siding. MP200 for the roof and MP175 for the siding. (MP175 sub package / MP200 sub package)*

Architect/Engineer Response: MP-200 standing seam panels manufactured by Metal Panel Systems is an approved equal for the metal panel roofing system as long as they can abide by all the requirements of the specifications including but not limited to being installed in continuous lengths without any lap joints. MP-175 standing seam panels manufactured by Metal Panel Systems is an approved equal for the metal panel roofing system as long as they can abide by all the requirements of the specifications. Note, under alternate #2 (Premanufactured Metal Building) all roof and wall panels are to be by the metal panel manufacture.

- 10) ***Bidder Question*** *What type of Pavement will be Placed for the Proposed Parking Lot, and is there a Detail for this Showing Depths and Stone Base?*

Architect/Engineer Response: The contractor can use owner supplied millings for new pavement areas where there are currently no asphalt millings. These new pavement areas shall consist of a minimum of 18 inches of asphalt millings. Asphalt millings may also be used to build up existing grades to meet proposed grades around the building.

Compaction equipment and methods used should be appropriate to adequately compact the millings in 6-inch maximum lifts. Prior to placement of any additional asphalt millings, the contractor shall work with the owner's geotechnical engineer to establish a procedure for the placement and compaction of asphalt millings.

ATTACHMENTS:

- REVISED BID FORM PAGE 12 ADDENDUM #4
- Revised Specification 01 21 00 ALLOWANCES and Appendix Attachments
 - i. Revised ALLOWANCE #2 Item #72 (per A1.1) - 2-Post Lift

***** END OF ADDENDUM NO. 4 *****



BID PROPOSAL FORM

To the: **Director of Public Service**
 Municipal Building
 5330 Seaman Road
 Oregon, Ohio 43616-2633

- I. The undersigned, having familiarized _____ with the local conditions affecting the cost of the work and with the Contract Documents, hereby proposes to perform everything required to be performed and to provide and furnish all of the labor, materials, necessary tools, expendable equipment, and all utility and transportation services necessary to perform and complete in a workmanlike manner all of the work required for the construction of an approximately 11,315 SF maintenance garage with a 690 SF mezzanine area (Base Bid) and a 1,957 SF wash bay addition (Alternate Bid). Work includes general trades, mechanical, plumbing, electrical, and miscellaneous work required to complete the project for the CITY OF OREGON, OHIO, all in accordance with the specifications for the following prices, to wit:

STREET DEPARTMENT GARAGE FACILITY - 2024
PROJECT BASE BID – ALL TRADES:

BASE BID PRICE IN FIGURES:	\$
ALLOWANCE #1 Item #2 - Air Compressor	ADD \$9,500.00
ALLOWANCE #2 Item #72 - 2-Post Lift	ADD <u>\$25,000.00</u>
ALLOWANCE #3 Item #74 - 4-Post Lift	ADD \$40,000.00

TOTAL PROJECT LUMP SUM BASE BID PRICE <u>PLUS</u> ALLOWANCES IN FIGURES:	\$
---	-----------

(Note: Bidders shall not add any conditions or qualifying statement to this Bid as otherwise the Bid may be declared irregular as not being responsive to the Advertisement for Bids.)

ALTERNATE BID ITEMS

The Bidder must fill in the applicable blanks with an increased or decreased amount for each Alternate Bid Item. The Owner reserves the right to accept or reject any or all bids on Alternates, in whole or in part, and in any order. If no change in the bid amount is required, indicate “No Change”.

1. PART I – GENERAL

1.1 RELATED DOCUMENTS

- A. Drawings and General Provisions of Contract, including General and Special Conditions and other Division 1 specification Sections, apply to Work of this Section.

1.2 SUMMARY

- A. Work with owner to purchase and have delivered to the site the following:
 - 1) Item #2 - Air Compressor
 - 2) Item #72 - 2-Post Lift
 - 3) Item #74 - 4-Post Lift
- B. See Appendix for additional information
- C. Designate in Construction Schedule delivery dates for these products.
- D. Designate in Contract Cost Breakdown the installation cost (to be included in base bid) of these items.
- E. The installation cost of these items shall be included in the Base Bid Price.

1.3 ALLOWANCES

- A. Provide Work under allowance as directed by owner in accordance with the Contract Documents.
- B. The following additional dollar amounts are included on the bid form and are to be added to the Base Bid Price for inclusion in Total Project Contract Sum:
 - 1) Item #2 - Air Compressor
 - a) Mi-T-M M Series 120-Gallon ADS-23110-120HM
 - b) Allowance: \$9,500.00
 - 2) Item #72 - 2-Post Lift
 - a) BendPak Two-Post Lift XPR-18CL or 20AP
 - b) Allowance: \$25,000
 - 3) Item #74 - 4-Post Lift
 - a) BendPak Four-Post Lifts HDS-40X
 - b) Allowance: \$40,000.00

C. Amount of Allowance includes:

- 1) Net cost of product as invoiced and paid by contractor
- 2) Delivery to the site from vendor as invoiced and paid by contractor
- 3) Applicable taxes (if any) as invoiced and paid by contractor

1.4 DELIVERY

A. Contractor Responsibility:

- 1) Arrange for delivery and unloading
 - a) Cost of unloading and handling the delivered material at the site by the contractor shall be included in the Base Bid Price
- 2) Promptly inspect product for damage or defects
- 3) Submit claims for transportation damage

1.5 INSTALLATION

- A. Install items per manufactures requirements.
- B. Cost of installation of each item shall be included in the Base Bid Price.

1.6 ADJUSTMENT OF CASH ALLOWANCES

- A. Unused amounts of monies included under allowances shall be credited to the Owner by deduct Change Order prior to approval of Final Application for Payment.
- B. The contractor shall notify the owner in writing as soon as they have knowledge that an allowance may be exceeded.

2. PART II – PRODUCTS (NOT APPLICABLE)

3. PART III – EXECUTION (NOT APPLICABLE)

◆ END OF SECTION ◆

ALLOWANCE #2

Item #72 (per A1.1) - 2-Post Lift

BendPak Two-Post Lift XPR-18CL or 20AP

BendPak®

16AP & 20AP

16AP | 16AP-192 **20AP** | 20AP-192

MADE STRONG™



16,000 Lb.
Lifting Capacity
16AP | 16AP-192

20,000 Lb.
Lifting Capacity
20AP | 20AP-192



Performance Guaranteed*

Telescoping Arms

High-Strength
Multi-Face Columns



360°
A.S.A.R.S.
AUTOMATIC
SWING ARM
RESTRAINT SYSTEM

1-800-253-2363 | WWW.BENDPAK.COM

© 2024 BendPak Inc. BendPak is a registered trademark.

*For comprehensive details about BendPak's 5-2-1 warranty, visit www.bendpak.com/support/warranty/.



PRODUCT DETAIL

Unleash Power and Precision

From heavy-duty fleet service to airport maintenance and emergency vehicle management, BendPak's 16AP and 20AP Series tackles them all. With plentiful 16,000 and 20,000 pound lifting capacities combined with long-reaching telescoping arms and a sizeable assortment of lifting adapters to accommodate virtually every chassis configuration, our Super-Duty AP Series makes an ideal supplement to existing fleet operations. Over 50 years of lift-building heritage perfectly delivered.

With oversize dimensions and capabilities that go well beyond those typically found on traditional two-post lifts, they lift more, lift higher, reach farther, and realize more vehicle-supporting stability than ever before. And with fewer moving parts, they're less susceptible to wear and tear, easier to maintain and less expensive to operate. And that all adds up to a cost-savings advantage you'll appreciate regardless of your environment. More uptime means more free time.



PERFORMANCE GUARANTEED*

America's best lift is coupled with the best warranty in the business. 5-Years on structure, 2-Years on the hydraulic cylinder(s) and power unit, 1-Year on operating components, electrical, labor, and ground-freight shipping.



50 PLUS YEARS

For over 50 years, BendPak has been pioneering service equipment technology as well as operational and supply systems that are now considered the standard for the entire industry.



Rugged Enough to Stand Up to Anything.

Every Super-Duty AP Series lift delivers the no-compromise construction, durability, and other advantages that only the industry's number one lift manufacturer can provide. Including the highest consumer confidence and safety rating, longest warranty, lowest cost of ownership and superior ergonomics that make your operators more productive and your operation more profitable. Bottom line, BendPak lifts are designed better, built better, and supported better than any other vehicle service lift in the world. Which explains why BendPak makes and sells more lifts than anyone. And why they also maintain the industry's highest resale value.



High-Strength Multi-Face Columns

Our revolutionary multi-face metal columns redefine strength and durability, especially under biaxial loading conditions. Unlike traditional single-formed columns, our innovative design incorporates multiple faces, strategically engineered to distribute loads more efficiently. This unique configuration enhances the structural rigidity and integrity of the columns, enabling them to withstand higher levels of stress and strain from varying directions simultaneously. By evenly dispersing forces during biaxial loading conditions, our multi-face columns provide unparalleled stability and resilience, ensuring optimal performance even in the most demanding environments, making them the ideal choice for any lifting application.



FEATURES

From accommodating large commercial trucks safer than ever before and lifting and supporting long awkward vehicles effortlessly, our Super-Duty AP Series handles heavy fleet tasks very comfortably. The key? Graciously spaced columns make for easier entry and exit and ruggedly built far reaching arms increase lifting point coverage delivering greater stability.

1. Power Unit

Electric-hydraulic power system with ergonomic push-button controls.

2. Extended Height

192 models offer extended height top-beam provides greater clearance.

3. Adapters Included

Comes with a 12-piece set of lifting adapters to suit your lifting needs.

4. Gunmetal Grey

Durable powder-coat finish gives the lift a sleek appearance.

5. Telescoping Arms

Versatile arms accommodates a wide variety of vehicle chassis.

6. Storage

Conveniently keep lifting adapters on the side of your lift and within arm's reach.

7. Shutoff Bar

Padded overhead safety shutoff bar automatically stops the lift should a vehicle make contact with the overhead structure.



ALI CERTIFIED

The gold ALI Certification badge is the leading nationally recognized standard for car lifts of all designs.

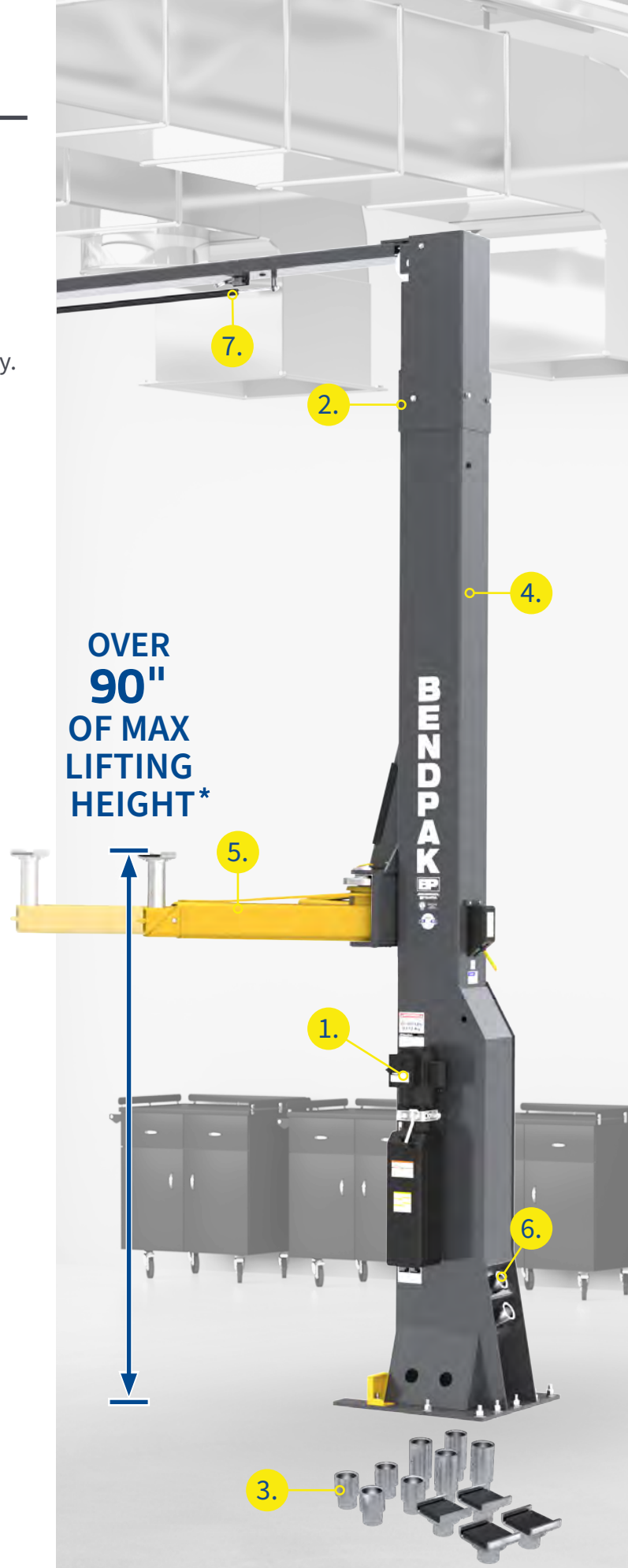

With an impressive rise that exceeds the industry standard, these lifts boast a maximum lifting height of over 90 inches. That means no more bending over or crouching while working beneath the vehicle. This ergonomic advantage not only enhances productivity but also significantly reduces the risk of back strain and musculoskeletal disorders and the potential for workplace injury claims.

8. Lift Dampener

Enjoy softer descents and enhanced safety.

9. Hydraulic Cylinders

The dual direct-drive cylinders result in smoother operation, and less maintenance.

10. Column Safety Locks

Placed every 4" ensures engagement during all lift operations.

11. Equalization System

Failsafe mechanical equalization system maintains equal lifting and provides operators a stable, level vehicle.

12. A.S.A.R.S

Full-perimeter 360-degree arm restraints stand alert at all times and keep the arms from moving when loaded.

13. Safety Lock

Redundant, failsafe mechanisms on each column reliably secure and always hold the lifting carriages and arm assemblies during operation.

14. UHMW

Each ultra-tall lifting carriage feature eight (UHMW ultra-high molecular weight polyethylene) load bearings to evenly disperse both radial and axial load forces throughout all lifting and lowering operations.

15. Columns

Multi-face metal columns redefine strength and durability, especially under biaxial loading conditions.



SPECIFICATIONS

Model	16AP	16AP-192	20AP	20AP-192
SKU	5175608	5175609	5175614	5175615
Lifting Capacity	16,000 lbs. / 7,257 kg		20,000 lbs. / 9,072 kg	
A – Under Clearance ¹ (Top Lock)	76 in. 1,930 mm	76 in. 1,930 mm	76.5 in. / 1,943 mm	
B1 – Max. Lifting Height ² (Top Lock)	82.25 in. / 2,089 mm		82.75 in. / 2,102 mm	
B2 – Max Rise ³	82.75 in. / 2,102 mm		83.25 in. / 2,114 mm	
C – Max. Lifting Height w/ Adapters ⁴	89.75 in. / 2,280 mm		90.25 in. / 2,292 mm	
D – Min. Height w/ Pad	7.75 in. / 195 mm		8 in. / 206 mm	
E – Overall Height	169 in. 4,294 mm	193 in. 4,904 mm	169 in. 4,294 mm	193 in. 4,904 mm
F – Overall Width	168 in. / 4,267 mm			
G – Outside Posts	149 in. / 3,785 mm			
H – Inside Posts	126 in. / 3,199 mm			
I – Drive-Thru Width	107.75 in. / 2,740 mm			
J – Floor to Top Switch	163 in. 4,128 mm	186.5 in. 4,738 mm	162.5 in. 4,128 mm	186.5 in. 4,738 mm
K – Lift Arm Reach ⁵	36 in. / 931 mm (min) 65 in. / 1,651 mm (max)		35 in. / 893 mm (min) 62 in. / 1,678 mm (max)	
L – Base Plate Width	28 in. / 710 mm			
M – Post to Base Plate	9.5 in. / 241 mm			
Max. load per Lift Arm	4,000 lbs. / 2,268 kg		5,000 lbs. / 2,268 kg	
Motor ³ / Sound	220 VAC, 60 Hz, 1 Phase / <70 dB			

(1) Under Clearance is to the bottom of the lift arms while engaged on top locks. (2) Max Lifting Height is with the locks engaged measured to the top of the pad. (3) Max Rise is distance raised to maximum vertical travel, above locks. (4) Max Lifting height is measured with adapters stacked and on top lock positions. (5) Lift Arms are measured from the Lift Arms axis of rotation to the Frame Cradle Pad mounting pin center. **Specifications subject to change without notice.**

Adapters

The 16AP and 20AP lifts come equipped with a comprehensive 12-piece set of lifting adapters, allowing seamless compatibility with a wide range of chassis configurations. This set includes (4) frame cradle pads, (4) medium stacking adapters, and (4) tall stacking adapters, ensuring versatile support for all your lifting needs. Keep them nice and organized with the included Adapter Holder.

Included



**Drop-In
Cradle Pads**
(Set of 4)
5215761



**5"
Tall Adapters**
(Set of 4)
5215759



**2.5"
Medium Adapters**
(Set of 4)
5215758

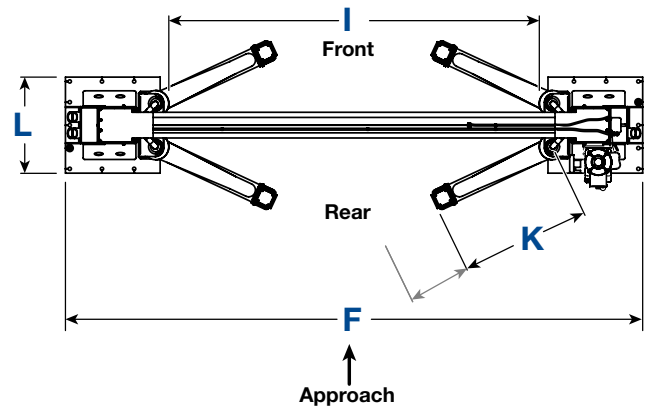
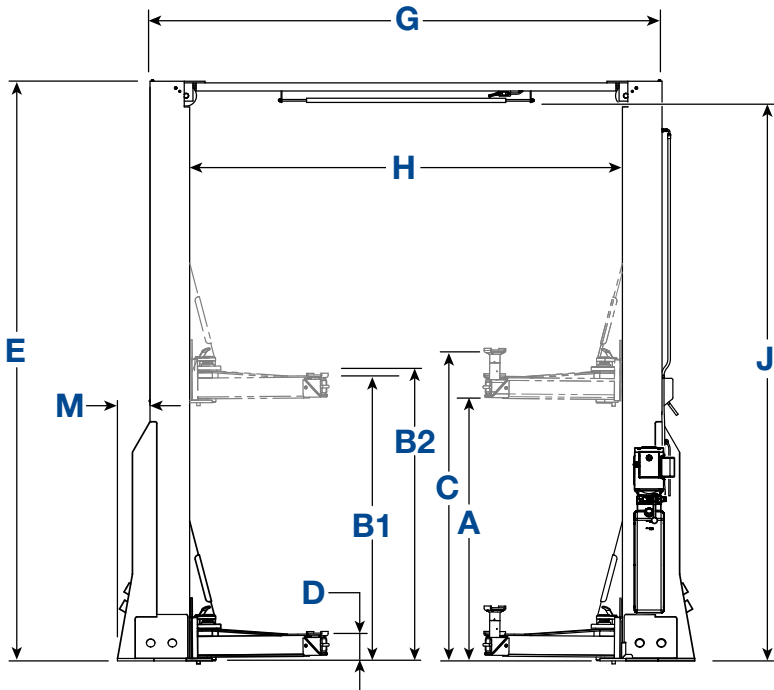

<p>Overall Height 169 in.</p> <p>Max. Lifting Height 89.75 in.</p> <p>16AP</p> <p>5175608</p>	<p>Overall Height 193 in.</p> <p>Max. Lifting Height 89.75 in.</p> <p>16AP-192</p> <p>5175609</p>	<p>Overall Height 169 in.</p> <p>Max. Lifting Height 90.25 in.</p> <p>20AP</p> <p>5175614</p>	<p>Overall Height 193 in.</p> <p>Max. Lifting Height 90.25 in.</p> <p>20AP-192</p> <p>5175615</p>
--	--	--	--